

HTM-next

Next generation of High Temperature Materials made by Plasma Metal Deposition for components in aircraft engines

Pier Paolo Curti MSc
RHP Technology GmbH
Vienna, 12.11.2025



Brief description of the consortium partners

RHP Technology [process & materials] is a solution provider for customized materials and advanced processing techniques based on powder technology as well as additive manufacturing.

AAC [testing & characterization] is active in the development and qualification of materials. Its main business covers testing services to various demanding industries including space and aeronautics.

SBI [Additive manufacturing machine development] a company specialized in high-tech welding solutions, with a core focus on plasma welding for applications such as joining, cladding, and 3D printing



Project Motivation

- **Flexible Additive Manufacturing of Ni-based Superalloys :** Plasma Metal Deposition (**PMD**) enables large, complex Ni alloy components to be printed efficiently with high deposition rates, supporting advanced high-temperature applications
- **Enabling next-generation aerospace performance:** Improved engine energy efficiency through lightweight, high-strength, and thermally stable structures.
- **Integrating innovation in material design:** Development of Ni alloys with ceramic reinforcement enhances mechanical and thermal properties, contributing to sustainability and material savings.

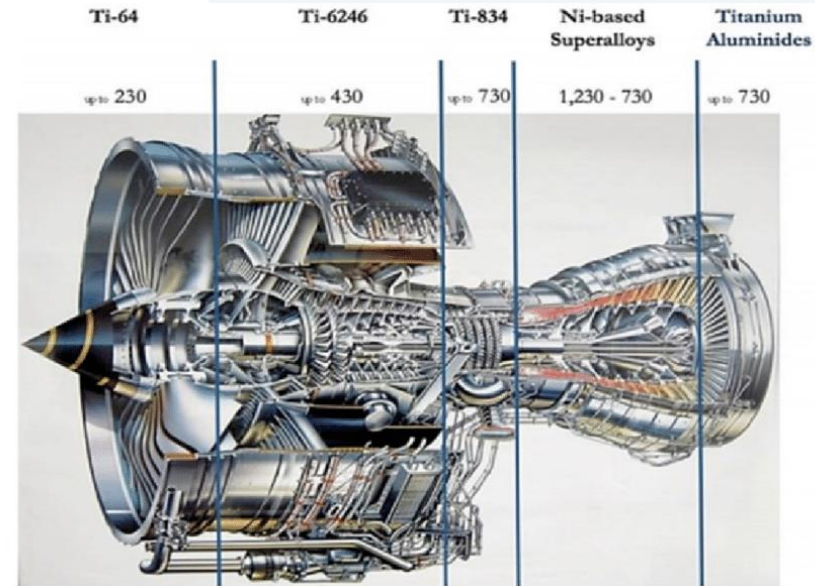

Aim of the Project

- **Develop and Optimize** the PMD to print (including torch modification) for high temperature resistant materials.
- Create and test **five alloy families** (Ni, Modified Ni, Intermetallics, HEA-Low, HEA-Extreme).

→Yield Strength > 200 MPa @ 1000 °C (Modified Ni)

→Yield Strength > 300 MPa @ 800 °C (Intermetallics)

→Yield Strength > 500 MPa @ 1000 °C (HEA)

- Build a **high-temperature tensile testing system** capable of **1200 °C** for rapid material evaluation
- Validate the PMD process through an **engine pylon demonstrator** achieving > **60 % material saving**.



PMD printing station



1000 °C tensile test device

Technology – Plasma Metal Deposition

- Plasma : Energy source
- Argon gas (Plasma and shielding)
- Wire feeding and Blown-powder-feed technique
- High feeding rate (1-10 kg/h)
- System attached to a Gantry (XYZ) system + Tilt/Turn Table
- Large size components: Working area of 1.5m x 2m

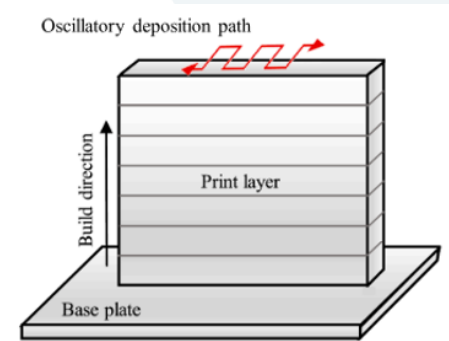
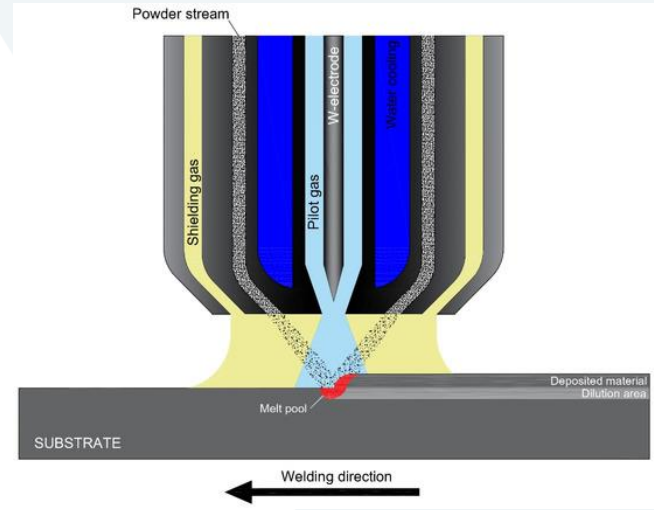

Project Results - Nickel Alloys and Modified Ni Alloys

Investigation of Modified Ni Alloys :

- PMD of a modified Ni alloy
- Ni-matrix composites with Al_2O_3 were also tested
-

Results:

- **Yield Strength of >200 MPa at 1.000°C achieved**
- Optimization of Heat Treatments required in order to improve the elongation

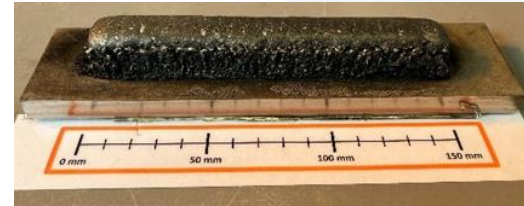

IN718 wall + 1vol% Al_2O_3 , cross section of the IN718 with embedded Allumina

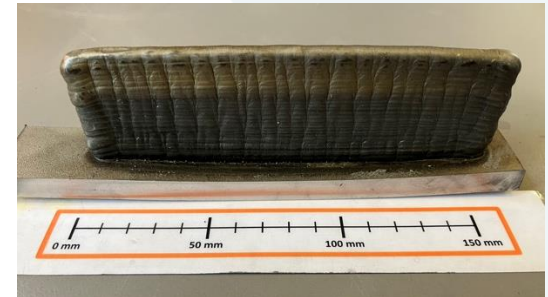

Ni alloy - AM test wall

Project Results - Intermetallics

PMD Processing of intermetallics

- Ti based
- **TNM** – Titanium Intermetallic
- **Low ductility (<2%)** remains a limitation; future work focuses on microstructure refinement and alloying (e.g. by addition of alloying elements).
- **Yield strength > 400 MPa @800°C** achieved

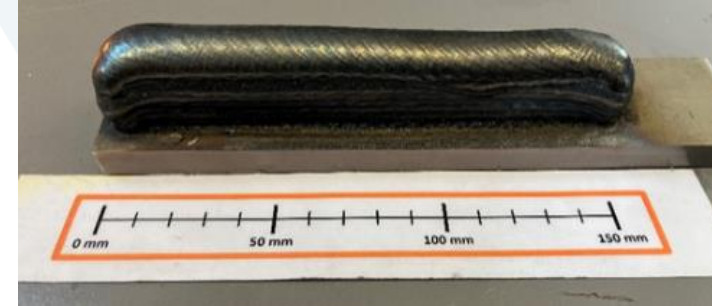

Project Results – High Entropy Alloy (HEA)

- Study of HEA materials *AlCoCrFeNi* and *AlCrMoNbTi*.
- Demonstrated **feasibility of multi-element alloying** via powder deposition.
- Refractory HEA *AlCrMoNbTi* produced dense structures with **dendritic morphology** and hardness up to **730 HV**.
- **Mechanical KPI not yet achieved** – further optimization of **heat treatment** and **feedstock design** required.

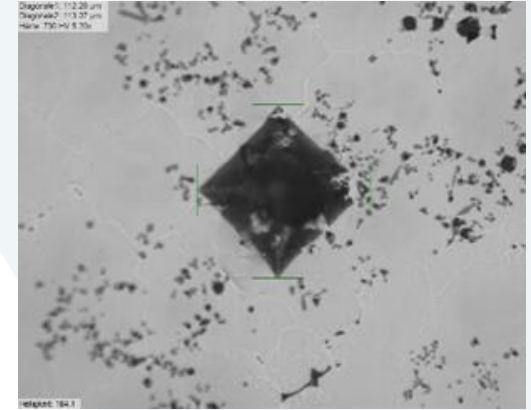

Hardness Indentation for the refractory HEA

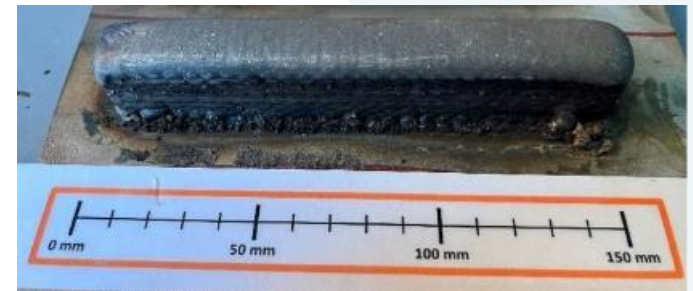

Refractory HEA wall (*AlCrMoNbTi*)

Project results

- **Demonstrator : Engine Pylon (Ni-alloy)**
- 400 × 130 mm pylon printed and partially milled.
- Material saving of ca. 50 % (16.8 kg vs 33 kg conventional machining from a block).

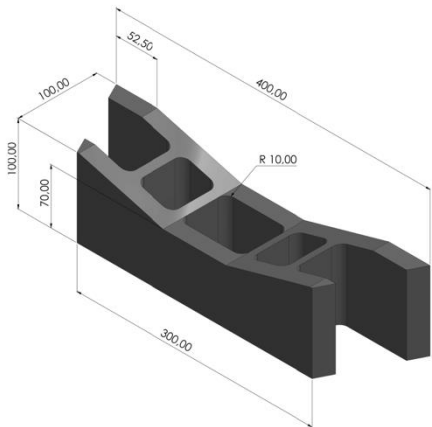
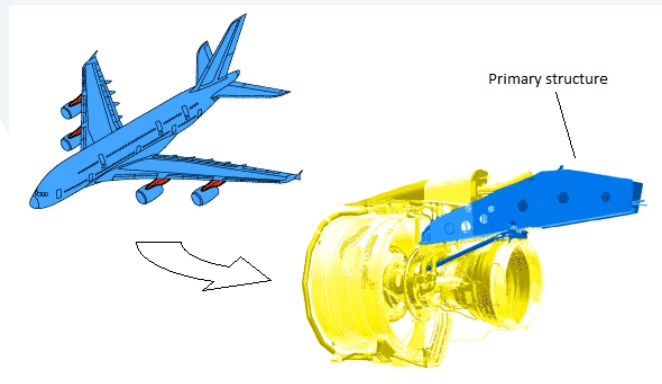

Utilization of the project

- PMD validated for large Ni-based components.
- Rapid high-temperature testing capability established at AAC (1200 °C).
- Results presented at major conferences:
 - **MAMC 2023**
 - **EURO PM 2024**
 - **ECSSMET 2024**
 - **FORMNEXT 2024**

Published and submitted papers:

- *Characterization of the Anisotropic Behaviour of Inconel 718 Parts Manufactured by WAAM – Superalloy 718 & Derivatives 2023*
- *Study of Thermal Mechanical Properties of Inconel 718 Reinforced with Ceramic Particles Manufactured by PMD – EURO PM 2024*
- *Assessment of the PMD Process for Additive Manufacturing of High-Temperature Alloys – ECSSMET 2024*
- *High-Temperature Performance of ABD 900 AM Processed by PMD – EURO PM 2025 (submitted)*

Further steps/(potential) follow-up projects

- **DOMINANT project (2025-27):** optimization of ABD 900 AM including new version of alloy with partners from UK.
- Future focus: heat treatment optimization, creep testing, multi-material deposition.
- Company contracts:
 - Feasibility/Assessment of HEAs for thruster nozzles
 - Feasibility on assessment of HEAs for glass-forming processes
 - Products: High Entropy Alloy Sputtering targets for thin film deposition